

## REVIEW

# Identification of QTL Controlling Allelopathic Effects in Rice: Genetic Approaches to Biological Control of Weeds

Kazutoshi OKUNO<sup>1\*</sup> and Kaoru EBANA<sup>2</sup>

Department of Genetic Resources I, National Institute of Agrobiological Resources  
(Tsukuba, Ibaraki 305–8602, Japan)

### Abstract

To analyze the genetic control of allelopathy in rice, we examined the quantitative trait loci (QTL) controlling allelopathic effects using a F<sub>2</sub> population of the cross between PI312777 and Rexmont, which exert highly suppressive and less suppressive effects respectively, on mono- and di-cot weed species in the field. The allelopathic effects were assessed using water-soluble leaf extracts from rice plants at the six-leaf growth stage. A highly positive correlation was detected between the suppressive effects of rice leaf extracts on the root growth of lettuce and duck salad. Seven QTL controlling allelopathic effects of rice on lettuce used as a test plant were identified on chromosomes 1, 3, 5, 6, 7, 11 and 12. One of the QTL on chromosome 6 exerted the largest effects on the expression of the allelopathic effects and explained 16.1% of the total phenotypic variation. The other 6 QTL explained the variation in the range from 9.4 to 15.1%. A multiple QTL model estimated that 5 QTL with LOD scores higher than 3.0 explained 36.6% of the total phenotypic variation. Digenic interactions in 5 pairs among 7 QTL were detected. In this paper, we examined the use of allelopathy in rice as a potential method for biological control of weeds.

**Discipline:** Plant breeding

**Additional key words:** allelopathy, *Oryza sativa* L., quantitative trait loci, RFLP mapping, water-soluble extracts

## Introduction

Allelopathy in rice could be used as a method for biological control of weeds in the rice ecosystems. Previous studies on rice allelopathy focused on the screening of allelopathic cultivars and the identification of allelochemicals. The allelopathic cultivars from rice germplasm collections were screened for the suppression of the growth of the weed species, duck salad (*Heteranthera limosa* (Sw.) Willd.)<sup>4</sup> and barnyardgrass (*Echinochloa crus-galli* P. Beauv.)<sup>15</sup>. The identification of allelopathic

rice has stimulated the genetic improvement of the weed-suppressing activity and breeding efforts are being made to incorporate the activity into elite rice cultivars<sup>3</sup>. However, the genetic mechanism of rice allelopathy has not been elucidated by conventional genetic analysis because the quantitatively inherited traits are controlled by multiple loci.

Recent advances in rice genome research have provided a powerful tool for the genetic analysis of quantitative traits. The use of a high-density genetic linkage map and of DNA markers mapped on rice chromosomes<sup>7</sup> may enable to identify the quantitative trait loci (QTL) con-

---

This study was partly undertaken within the framework of the joint project between National Institute of Agrobiological Resources (NIAR) and Dale Bumpers Rice Research Center, USDA-ARS sponsored by the Science and Technology Agency.

Present address:

<sup>1</sup> Department of Low-Temperature Sciences, National Agricultural Research Center for Hokkaido Region (Sapporo, Hokkaido 062–8555, Japan)

<sup>2</sup> Genebank, National Institute of Agrobiological Sciences (Tsukuba, Ibaraki 305–8602, Japan)

\*Corresponding author: fax +81–11–859–2178; e-mail [okusan@affrc.go.jp](mailto:okusan@affrc.go.jp)

Received 30 October 2002; accepted 22 January 2003.

trolling the allelopathic effect of rice on weeds. Interval mapping of the allelopathic QTL can contribute to DNA marker-assisted selection for the weed-suppressing activity and positional cloning of individual QTL for the allelopathic effect. Four main QTL for the allelopathic effect of rice on barnyardgrass were found to be located on 3 rice chromosomes and they explained 35% of the total phenotypic variation of the allelopathic effect<sup>8</sup>.

To identify the QTL controlling rice allelopathy, we attempted to develop a bioassay to assess the allelopathic effect of rice on the weed ducksalad and on lettuce<sup>5</sup>. The bioassay for the QTL analysis consisted of using water-soluble extracts from rice seedlings at the six-leaf growth stage and lettuce, the most sensitive plant to allelopathic compounds, as the test plant. Lettuce was selected as the test plant based on the highly positive correlation between the allelopathic effects of rice extracts on ducksalad and lettuce, and because lettuce reacted to the chemical compounds present in the extracts in a more stable way than ducksalad. This paper reports the analysis of the QTL controlling the allelopathic effects of rice on lettuce using DNA markers<sup>6</sup>.

## Materials and methods

### 1. Plant materials

A cross was made between 2 rice cultivars, namely PI312777 (*indica* cultivar which exerts a highly suppressive effect on weeds) and Rexmont (*japonica* cultivar which exerts a less suppressive effect on weeds). PI312777 is a true-breeding line derived from the cross combination, Taichung 65\*2/Taichung Native 1 and Rexmont is a commercial cultivar developed in the southern part of USA. To isolate DNA, the leaves from 192 F<sub>2</sub> plants grown in the field were individually sampled. Thirty F<sub>3</sub> seeds per each F<sub>2</sub> plant were sown in a pot and the leaves were sampled from F<sub>3</sub> seedlings at the six-leaf growth stage. The leaf samples from 2 replicates were bulked and used to extract water-soluble unidentified compounds.

### 2. Extraction of water-soluble compounds

Fresh leaves harvested from the F<sub>3</sub> seedlings were freeze-dried, ground to a powder using a mortar and a pestle and finally stirred in cold distilled water. Ten mL of water per g fresh leaves were added to the samples. The mixture was stirred on a rotary shaker for 1 h after being kept in a refrigerator for 2 h and then centrifuged at 1,500 rpm for 15 min. The supernatant was recovered and used to assess the allelopathic effect as crude water-soluble extract.

### 3. Assessment of allelopathic effects

Fifty seeds of the lettuce cultivar Great Lakes 366 were placed on a filter paper in a 9 cm diameter petri dish. Three mL of the crude extract or sterilized distilled water as the control were applied to lettuce seeds. Petri dishes were sealed and incubated at 25°C in the dark for 3 days. The length of the roots of 10 randomly selected germinating seeds was measured in 5 replications for each extract and 2 replications per each F<sub>3</sub> line. The percentage of the root length of the lettuce seedlings to the control was used as the parameter to evaluate the allelopathic effects. All the data were processed by SAS for the basic statistics<sup>19</sup>.

### 4. Analysis of DNA polymorphism

Total DNA was isolated from the leaves of individual F<sub>2</sub> plants using the CTAB method<sup>13</sup>. DNA isolated was digested with 8 restriction enzymes, *Apa*I, *Bam*HI, *Bgl*II, *Dra*I, *Eco*RI, *Eco*RV, *Hind*III and *Kpn*I. Digested DNA was transferred to a positively charged nylon membrane after electrophoresis. Southern hybridization and signal detection were performed using ECL direct nucleic acid labeling and a detection kit (Amersham Pharmacia Biotech). A total of 215 RFLP probes were surveyed for a probe-enzyme combination showing polymorphism between the parental cultivars. Among the 215 RFLP probes, 192 probes from the linkage map which was constructed with the mapping population from the cross between Nipponbare and Kasalath, were provided by the DNA Bank at the National Institute of Agrobiological Sciences, Japan. Other 23 probes were selected from the linkage map reported<sup>9</sup> and supplied by the Rice Genome Research Program, Japan.

### 5. Data analysis

Phenotypic values of each F<sub>3</sub> line were represented by the mean values of the root length. The program MAPMAKER/EXP ver. 3.0b<sup>11</sup> based on Kosambi function was used for constructing the RFLP linkage map. The program MAPMAKER/QTL ver. 1.0<sup>10</sup> was applied to identify the allelopathic QTL and also to obtain estimates of the percentage of phenotypic variation explained by each quantitative trait locus. PROC GLM in the computer program SAS<sup>19</sup> was used to determine the relationship between the RFLP markers and the allelopathic effects. Putative QTL controlling the allelopathic effects were identified by the LOD threshold of 2.0 in MAPMAKER/QTL and 5% significance level in PROC GLM analysis. PROC GLM was also used to analyze the possible digenic interaction between the closest RFLP marker loci to individual QTL.

## Results

The allelopathic effects of each  $F_3$  line were determined based on the suppression of the root length of the lettuce plants treated with water-soluble leaf extracts from rice plants at the six-leaf growth stage. The frequency distribution of the allelopathic effects in the  $F_3$  lines was continuous, ranging from 3.3 to 39.5% of the control with the mean value of  $15.4 \pm 5.02\%$  (Fig. 1). The root length of the lettuce seedlings treated with the extract from PI312777 and Rexmont was  $5.8 \pm 1.42\%$  and  $28.7 \pm 4.14\%$  of the control, respectively. The values of the allelopathic effects in most of the  $F_3$  lines were distributed between the parental cultivars except for a small number of lines.

Out of 215 RFLP probes surveyed, 125 probes which generated polymorphic bands between PI312777 and Rexmont, were used for QTL analysis. A map of 12 linkage groups constructed in this study covered a genetic distance of 1336.2 cM (Fig. 2). The percentage of polymorphic probes between PI312777 and Rexmont to the total number of probes surveyed ranged from 12.7 to 76.4% among the 12 chromosomes. The gaps which corresponded to the chromosomal regions without RFLP markers were found on chromosomes 1, 3 and 10.

The analysis with MAPMAKER/QTL revealed the presence of 7 QTL controlling the allelopathic effects of rice with LOD scores higher than 2.0 located on chromo-

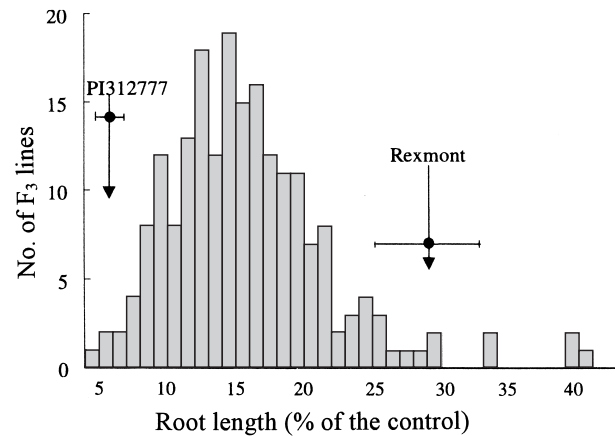

Fig. 1. Frequency distribution of root length of lettuce treated with water-soluble leaf extracts of rice<sup>6</sup>

somes 1, 3, 5, 6, 7, 11 and 12 (Table 1, Fig. 2). Each of the 7 QTL explained 9.4 to 16.1% of the total phenotypic variation. The closest RFLP markers to each quantitative trait locus for the allelopathic effects were *R2159* on chromosome 1, *R1925* on chromosome 3, *R830* on chromosome 5, *R1167* on chromosome 6, *R2401* on chromosome 7, *G257* on chromosome 11 and *R1709* on chromosome 12, respectively. The RFLP markers were significant at the 5% level based on the analysis using SAS/GLM. A multiple QTL model estimated that 5 QTL with LOD scores higher than 3.0 explained 36.6% of the

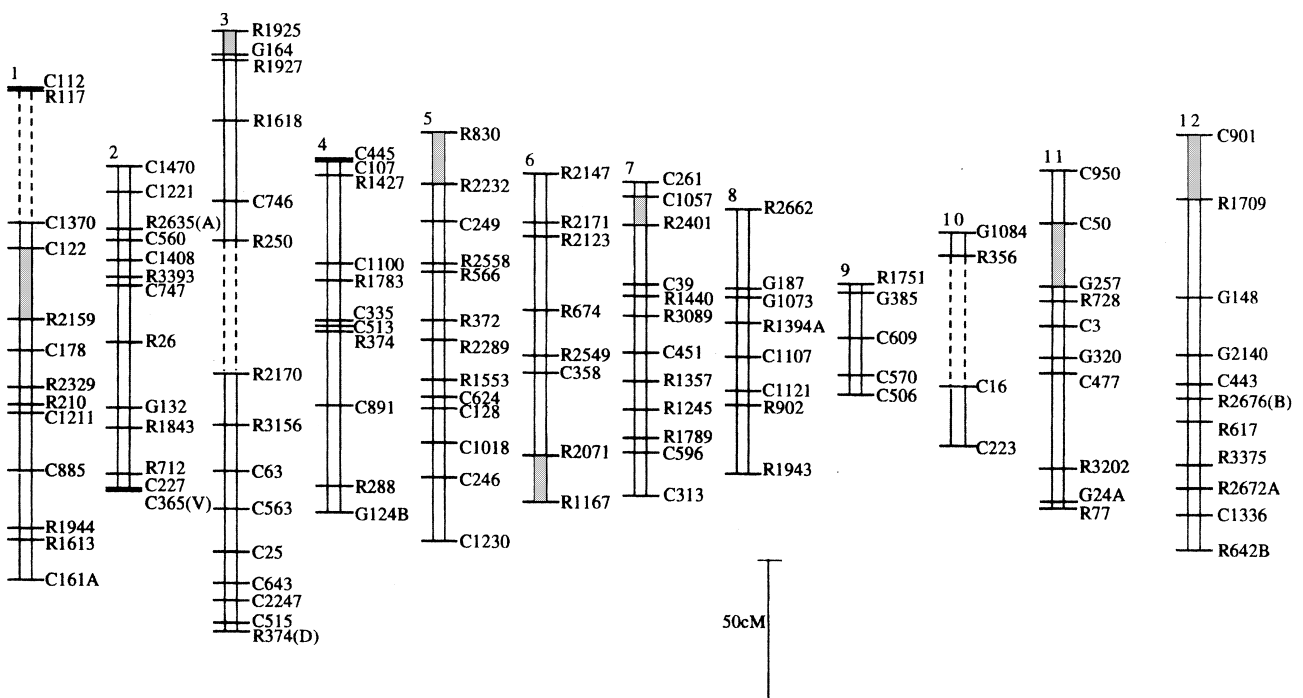

Fig. 2. Genetic linkage map and positions of QTL for allelopathic effects of rice<sup>6</sup>

Filled bars denote the putative regions of QTL with LOD scores higher than 2.0 in MAPMAKER/QTL.

**Table 1. Putative QTL for growth-suppressive effect of rice leaf extracts on lettuce roots<sup>6</sup>**

Chromosome	Closest DNA marker	Position (cM) <sup>a)</sup>	LOD	var. exp.(%) <sup>b)</sup>	Additive effect	Dominance effect	SAS
1	<i>R2159</i>	-7	2.58	9.6	-1.72	-2.6	*
3	<i>R1925</i>	2	3.74	10.4	-2.37	-0.23	**
5	<i>R830</i>	8	4.01	13.2	-2.25	-2.78	*
6	<i>R1167</i>	-7	4.03	16.1	-2.72	-3.61	**
7	<i>R2401</i>	-7	3.99	15.1	-2.78	-2	**
11	<i>G257</i>	-8	2.74	9.4	-2.3	-1.26	**
12	<i>R1709</i>	-13	3.14	12.5	-2.59	-2.37	**

a): Negative and positive values. QTL located upstream and downstream from the closest marker locus, respectively.

b): Phenotypic variation explained by each locus.

\*\*Association between the marker and phenotype is significant at the 1% level of probability with SAS GLM PROC.

\*Significant at the 5% level of probability.

phenotypic variation. The F<sub>3</sub> lines with the PI312777 allele at all the closest RFLP marker loci to each quantitative trait locus exerted a more suppressive effect on the growth of lettuce roots than the F<sub>3</sub> lines with the Rexmont allele. Dominance effect which was found in the QTL linked to the RFLP markers *R2159* (chr. 1), *R830* (chr. 3), *R1167* (chr. 6) and *R1709* (chr. 12), suggested that the PI312777 allele was dominant over the Rexmont allele at these QTL.

The analysis with SAS/GLM PROC showed that the closest RFLP markers to each quantitative trait locus interacted with one another. Interactions in 5 combinations between *R1167* (chr. 6) and *R2401* (chr. 7), between *R2401* and *R830* (chr. 5), between *R830* and *R1925* (chr. 3), between *R1925* and *R1709* (chr. 12) and between *R1925* and *G257* (chr. 11) were significant at the 1% level of probability. The other 4 combinations between *R2401* and *G257*, *R1709* and *R2159*, *R1925* and *R2159*, and *R1709* and *G257* were significant at the 5% level of probability.

## Discussion

Weed control is one of the major constraints in most of the rice-growing areas worldwide. For instance, duck-salad, which is one of the main weeds in the southern part of USA, caused a 21% yield reduction in direct-seeded rice<sup>20</sup>. Although various kinds of chemical herbicides are applied to control weeds, recent efforts aim at decreasing the amount of herbicides applied to the rice ecosystems because of their cost and adverse effects on the environment. However, rice growers can not apply useful methods for biological weed control in contrast to the success in the genetic improvement of the resistance to pests and diseases. Allelopathy in rice could become a biological method for weed control. In the 1990s, allelopathy

research in rice focused on the screening of weed-suppressing rice cultivars in the field or laboratory and also on the identification of chemical compounds. Some rice cultivars induced a weed-free area within a radius of 10 to 15 cm around individual plants and suppressed the growth of an aquatic weed, ducksalad, in field experiments<sup>4</sup>. Other rice cultivars also suppressed the growth of barnyardgrass in field experiments and laboratory bioassays<sup>15</sup>. In future, research on rice allelopathy will be mainly focused on the identification of allelochemicals and isolation of genes controlling allelopathic effects from the viewpoint of practical utilization of allelopathy under field conditions<sup>14</sup>.

We first developed a bioassay to assess the allelopathic effects of rice on ducksalad and lettuce as test plants using water-soluble leaf extracts from rice plants<sup>5</sup>. There was a highly positive correlation between the suppressive effects of rice leaf extracts on the root growth of ducksalad and lettuce. As lettuce reacted to the chemical compounds present in the water-soluble extracts from rice leaves in a more stable way than ducksalad, lettuce was used for the analysis of the QTL controlling the allelopathic effects.

Genetic approaches to rice allelopathy are essential for the identification of allelopathic QTL, DNA marker-assisted selection for allelopathic effects and map-based cloning of allelopathy genes. The studies on the rice genome have produced and provided molecular genetic tools needed to identify the QTL for allelopathic effects of rice. Using RFLP markers derived from the rice genome studies, we identified 7 QTL for the growth suppression of lettuce roots. At all the closest RFLP marker loci to the allelopathic QTL, the PI312777 allele was found to exert a more suppressive effect on the growth of lettuce than the Rexmont allele. Among the 7 QTL identified, the quantitative trait locus on chromosome 6

expressed the highest level of allelopathic effects on lettuce, suggesting that this locus plays a major role in rice allelopathy. A multiple QTL model indicated that 5 QTL with LOD scores higher than 3.0 on chromosomes 3, 5, 6, 7 and 12 explained 36.6% of the total phenotypic variation, compared to 35% in the case of allelopathic upland rice against barnyardgrass<sup>8</sup>. These low values suggest the presence of unidentified QTL, due to the lack of RFLP markers in some chromosomal regions. The gaps in the linkage map constructed in this study were detected on chromosomes 1, 3 and 10, reflecting the genetic similarity between PI312777 and Rexmont which harbor Taichung Native 1 in their genetic background. Highly polymorphic mapping populations are required for further analysis of rice allelopathy. In addition, comparative analysis between the QTL controlling the allelopathic effects and the amount of allelochemicals synthesized in rice plants may lead to a better understanding of the mechanisms controlling rice allelopathy.

Chemical compounds associated with allelopathic effects are synthesized through the secondary metabolism pathway<sup>17</sup>. In rice, aqueous extracts of decomposing residues in soil inhibited the growth of rice roots and lettuce seedlings<sup>2</sup>. Six phenolic acids were isolated from decomposing rice straw and paddy soil<sup>1</sup>. A total of 16 potential compounds involving phenolic acids were detected in rice<sup>16</sup>. The chemical compounds with allelopathic effects on barnyardgrass were isolated from rice leaves by HPLC<sup>12</sup> and roots by GC-MS<sup>18</sup>. These chemical approaches have provided the candidate compounds associated with rice allelopathy. Further fractionation is being undertaken to isolate and identify active chemical compounds which are primarily responsible for rice allelopathy. The comparative analysis of the allelochemicals identified by the above-mentioned reports and the analysis of the QTL controlling their synthesis are both essential for achieving progress in rice allelopathy research.

QTL analysis is the first step in the genetic analysis of rice allelopathy and in the setup of genetic improvement strategies, with emphasis placed on biological weed control under rice field conditions. Closely linked DNA markers to the QTL identified here will be further used for producing near-isogenic lines with each quantitative trait locus. The use of these lines may enable to promote genetic analysis of rice allelopathy, DNA marker-assisted selection for allelopathic effects and map-based cloning of allelopathic QTL.

## References

1. Chou, C. H. (1980) Allelopathic researches in the subtropical vegetation in Taiwan. *Comp. Physiol. Ecol.*, **5**, 222–234.
2. Chou, C. H. & Lin, H. J. (1976) Auto-intoxication mechanism of *Oryza sativa* L.: I. Phytotoxic effects of decomposing rice residues in soil. *J. Chem. Ecol.*, **2**, 353–367.
3. Courtois, B. & Olofsdotter, M. (1998) Incorporating the allelopathy trait in upland rice breeding programs. *In Allelopathy in Rice*. ed. Olofsdotter, M., IRRI, Manila, Philippines, 57–67.
4. Dilday, R. H., Lin, J. & Yan, W. G. (1994) Identification of allelopathy in the USDA-ARS rice germplasm collection. *Aust. J. Exper. Agric.*, **34**, 901–910.
5. Ebana, K. et al. (2001) Variation in allelopathic effect of rice (*Oryza sativa* L.) with water-soluble extracts. *Agron. J.*, **93**, 12–16.
6. Ebana, K. et al. (2001) Analysis of QTL associated with the allelopathic effect of rice using water-soluble extracts. *Breed. Sci.*, **51**, 47–51.
7. Harushima, Y. et al. (1998) A high-density rice genetic linkage map with 2275 markers using a single F<sub>2</sub> population. *Genetics*, **148**, 479–494.
8. Jensen, L. B. et al. (2001) Locating genes controlling allelopathic effects against barnyardgrass in upland rice. *Agron. J.*, **93**, 21–26.
9. Kurata, N. et al. (1994) A 330 kilobase interval genetic map of rice including 883 expressed sequences. *Nature Genet.*, **8**, 365–372.
10. Lander, E. S. & Botstein, D. (1989) Mapping Mendelian factor underlying quantitative traits using RFLP maps. *Genetics*, **121**, 185–199.
11. Lander, E. S., Green, O. & Abrahamson, J. (1987) MAP-MAKER An interactive computer package for constructing primary genetic linkage maps of experimental and natural populations. *Genomics*, **1**, 174–181.
12. Mattice, J. D. et al. (2001) Barnyardgrass growth inhibition with rice using high-performance liquid chromatography to identify rice accession activity. *Agron. J.*, **93**, 8–11.
13. Murray, M. G. & Thompson, W. F. (1980) Rapid isolation of high molecular weight plant DNA. *Nucleic Acid Res.*, **8**, 4321–4325.
14. Olofsdotter, M. (2001) Rice – a step toward use of allelopathy. *Agron. J.*, **93**, 3–8.
15. Olofsdotter, M. & Navarez, D. (1996) Allelopathic rice in *Echinochloa crus-galli* control. *In Proc. 2<sup>nd</sup> Int. Weed Control Cong.*, eds. Brown, H. et al., DJF, Flakkebjerg, Denmark, 1175–1181.
16. Olofsdotter, M., Navarez, D. & Moody, K. (1995) Allelopathic potential in rice (*Oryza sativa* L.) germplasm. *Ann. Appl. Biol.*, **127**, 543–560.
17. Rice, E. L. (1974) *Allelopathy*. Academic Press, New York, USA, pp.353.
18. Rimando, A. M. et al. (2001) Searching for rice allelochemicals: an example of bioassay-guided isolation. *Agron. J.*, **93**, 16–20.
19. SAS Institute (1989) SAS/STAT user's guide: version 6.03, vol.2. 4<sup>th</sup> ed. SAS Institute Inc., Cary, North Carolina, USA.
20. Smith, R. J. (1988) Weed threshold in southern US rice *Oryza sativa*. *Weed Technol.*, **2**, 232–241.