

Acoustic Characteristics of Fresh Tea Leaves

Mikio FUKUHARA^{1*}, Limi OKUSHIMA², Kiyoshi MATSUO³ and Tomoo HOMMA⁴

¹ Materials and Components Division, Tungaloy Co.,Ltd. (Kawasaki, Kanagawa 212–0057, Japan)

² Department of Program Management and Coordination, National Institute for Rural Engineering (Tsukuba, Ibaraki 305–8609, Japan)

³ Department of Physiology-Hereditry, National Institute of Vegetable and Tea Science (Kanaya, Shizuoka 428–0022, Japan)

⁴ Tokyo Medical and Dental University (Chiyoda, Tokyo 101–0062, Japan)

Abstract

The acoustic characteristics of sound fresh tea leaves were determined nondestructively by ultrasonic transmission analysis. As thickness increases, phase velocity and wavelength increase, and damping ratio and dynamic viscosity decrease, suggesting development of the fibrous tissues, accompanied by frequency convergence. The velocities of all the leaves studied were smaller than that of pure water. Decrease in viscoelasticity corresponds to increase in dynamic modulus. Thus, acoustically, we can regard the leaves as natural quasi-polymers with high viscoelasticity.

Discipline: Horticulture

Additional key words: ultrasonic transmission analysis, viscoelasticity, natural quasi-polymers

Introduction

Ultrasonic techniques are useful for analyzing and evaluating physical characteristics such as velocity, damping and elasticity^{4–6}. They also have many medical applications. However, few applications of these characteristics have been made in biological fields such as agricultural and plant science. In this paper, we shall discuss the application of ultrasonic techniques to the biophysical evaluation of fresh tea leaves in terms of their viscoelasticity, as associated with the complex waves. Tea is a popular and medicinal drink enjoyed by many people all over the world. Since the leaves are the most active part of the tea plant, they provide important and useful information concerning the plant's maturation. When the tea leaves are processed as tea products, their physical properties have great influence upon the harvest timing, the process operation and quality of the products. These physical parameters may be used to set minimum quality standards. Especially, leaf thickness, one of the physical parameters, reflects many factors such as hardness, density, water potential¹⁷ and photosynthetic characteristics¹⁵. In this study, thickness in fresh tea leaf was investigated

by analogy of polymers properties.

In Fukuhara et al.^{7,8}, we reported a relation between ultrasonic propagation time and hardness for some kinds of plant leaves, using longitudinal ultrasonic waves passing through the leaves suspended in water. And then the acoustic characteristics of 111 kinds of leaves were determined by the same method⁹. It is called "Vibrating Resonance Penetration (VRP)" method. The VRP method is capable of providing an acoustic evaluation of the fundamental characteristics of fresh leaves, which are a dispersive media. However, as far as we know, we are the first to have carried out research on this subject. We further investigate relations between acoustic properties and development of tissues as a function of thickness, i.e., degree of maturation, for fresh tea leaves, using the VRP method.

Materials and methods

1. Plant material and ultrasonic apparatus

Tea leaves were picked from the tip of the twig at an interval of one twig per five branches of each tree (*Camellia sinensis* (L) O. Kuntze cv. Yabukita). After the leaves were picked, micro bubbles of air were removed

*Corresponding author: fax +81-44-587-2670 ; e-mail a80010@tungaloy.co.jp

Received 25 June 2004; accepted 21 September 2004.

from the surface of the leaves by ultrasonic vibration for 20 s. Wave transmission measurements were performed between 20 and 60 seconds after the leaves were picked since the acoustic characteristics of leaves gradually change by water invasion into levels during immersion in water. Thickness was measured using a micrometer. Density was calculated from weight, surface area and thickness. The surface area was converted from weight of paper of leaves, which were copied by Xerox machine. Phase velocity, frequency and damping ratio were determined from through-sample and reference (water path-only) signals by comparing the magnitudes and phases of their Fourier coefficients using an ultrasonic diagnosis and analyzer (USH-B, Toshiba Tungaloy) with a transmitter/receiver set at 298 K. The apparatus and block diagram for measurement are presented schematically in Fig. 1. The pulser was applied by the electric power of 200V. The time clock fluctuation error of the circuit signal between the pulser and the receiver was reduced by the usage of synchronized PCI boards. Accuracy of reading of flight time is ± 50 ps. Facing broad-bandwidth longitudinal wave transducers of 3.3 MHz in frequency and 4 mm in diameter were used as the transmitter and the receiver. To suppress the phase modulation that occurred at the boundary between the leaf surface and water, planar PZT transducers were used. The leaf was suspended between two facing transducers, which were separated 9 mm in water^{8,9}. The wave transmission was

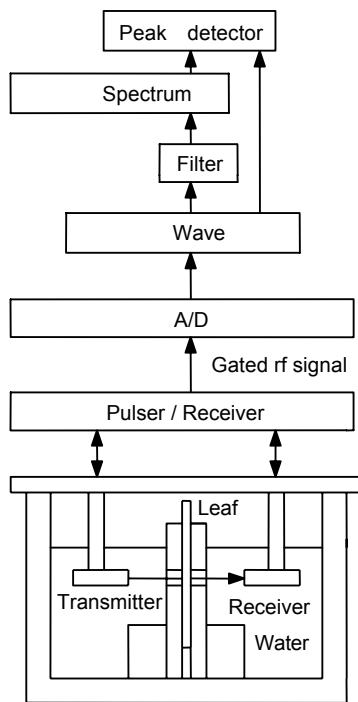

Fig. 1. The apparatus and block diagram for measurement

carried out from the front surface of the leaf to the back at three points on the midrib and at two on the leaf blade.

2. Ultrasonic measurement

The phase velocity can be used for the biophysical evaluation of dispersive media such as soft and uneven leaves in place of the conventional group velocity. The phase velocity^{2,20} was calculated using the following formula:

$$V_p = \frac{V_w}{1 - \frac{V_w \cdot \Delta\phi \cdot (\omega)}{\omega d}} \tag{1}$$

where phase shift $\Delta\phi = \phi_w - \phi$ is the difference between the phase angle ϕ in the sample spectra of the through-sample and reference traces, and ω and d are the angular frequency ($= 2\pi f$) and thickness. V_w is the sound velocity (1,497.0 m/s at 298 K) of water¹⁶. Fourier transformation of the digitized receiving waveforms from the dispersive media was carried out to determine the main frequency f and phase ϕ at f . To match the frequency of the test and the reference signals, we used the frequency (f_w) of 1.6 MHz for water and phase (ϕ_w) of 0.0019 rad. at f_w . The phase shift $\Delta\phi$ is defined as:

$$\Delta\phi = \arctan [Im(\omega_w)/Re(\omega_w)] - \arctan [Im(\omega)/Re(\omega)], \quad (0 < \phi < \pi/2) \tag{2}$$

where $Re(\omega)$ and $Re(\omega_w)$, $Im(\omega)$ and $Im(\omega_w)$ are the real and imaginary parts of complex waves passing through the sample and water, respectively. Since all the phase observed at f lay in between 0 and $\pi/2$, the unfolding problem was avoided. The form determined the attenuation coefficient α and the damping ratio δ of the samples:

$$\alpha = \frac{\delta}{d} = \frac{\ln(A_1/A_2)}{d} \tag{3}$$

where A_1 and A_2 are amplitudes of the first and the second wavelets for receiving wave patterns, respectively. The correlation coefficients between two random parameters were calculated by the standard method of least squares. The Nyquist diagram was plotted in the complex plane of the open-loop transfer (propagation) wave function for all the complex frequencies in counterclockwise, using a vector locus¹⁹.

Results and discussion

1. Wave velocity and dynamic modulus for development of the leaf's tissue

The thickness dependence of the phase velocity and wavelength of the tea leaves are shown in Fig. 2. The phase velocity smoothly increases with increasing thick-

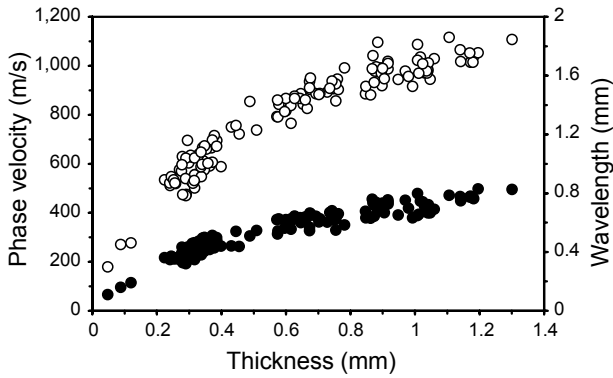

Fig. 2. The thickness dependence of phase velocity and wavelength for tea leaves

○ : Phase velocity, ● : Wavelength.

ness. We thus can gather that ultrasonic wave propagates more easily through the hard surfaces and developed fibrous tissues of leaves than through thin softer leaves. The wavelengths are almost equivalent to their thickness up to 0.5 mm, and then increase with slope of 0.4 in thickness between 0.5 mm and 1.0 mm. As can be seen from the internal structure of a dicotyledonous leaf³, the standing wave with the second harmonic mode occurs in leaves of thickness d fixed at three points on the surfaces and the vein up to thickness of 0.5 mm, and over 0.5 mm the wave with higher order mode proceeds due to development of an extensive network throughout the leaf. The trait relates to growth of tea leaves.

The velocity of the leaves was less than that (1,497.0 ms^{-1} at 298 K) of pure water, even though the texture of the tea leaf is not like fine foamy bulk such as found in leaves of a water hyacinth. We can posit two causes for this. One possible cause is that main internal structure of the leaves is characterized by loosely packed parenchyma cells separated by intercellular air spaces³. The other possibility is that the mechanical contact required in making the thickness measurement causes sample deformation, making it difficult to determine the sound speed in leaves with high accuracy. It will be probably the former, because of the hard leaves. However, for thin softer leaves, we cannot explain lower phase velocity than that (340 m/s) of air at present time. A detailed study is needed.

As can be seen from Eq.(1), the phase velocity in Fig. 2 also shows that the more delayed the phase is, the greater the phase velocity becomes. Here it should be noted that the viscoelastic properties of polymers⁴⁻⁶, naphthenic hydrocarbon oils with high viscosity¹⁰ and high damping alloy, $\text{Mn}_{73}\text{Cu}_{20}\text{Ni}_5\text{Fe}_2$ ¹¹ could be evaluated from their phase modulation in complex waves. The phase modulation of fresh tea leaves, like soft polymers

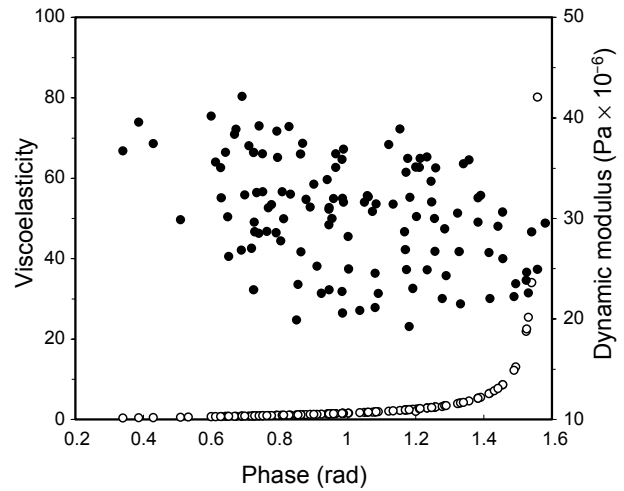

Fig. 3. The phase dependence of viscoelasticity and dynamic modulus for tea leaves

The correlation coefficient between phase and dynamic modulus is 0.561.

○ : Viscoelasticity, ● : Dynamic modulus.

(e.g. rubber), must involve a Newtonian viscous component to the elastic response: such a situation is denoted as viscoelasticity, associated with complex waves¹⁴. The viscoelastic parameter $\tan \phi(\omega)$ is presented by the phase shift $\Delta\phi$ in Eq.(2).

Equation (2) can be synonymously expressed by a complex modulus M^* ¹⁸.

$$M^* = M_1 + i\omega\eta \quad (4)$$

where $M_1 (= \rho V_p^2)$ is a dynamic modulus and $\eta (= 2\rho\alpha V_p^3/\omega^2)$ is a dynamic viscosity, where ρ is density. In case of general glass polymer, we can regard as $\alpha V_p/\omega \ll 1$. We first investigate properties of the leaves in terms of elasticity. The phase dependence of viscoelasticity and dynamic modulus are shown in Fig. 3. As the phase angle increases, the viscoelasticity exponentially increases and the dynamic modulus gradually decreases with wide dispersion ($r = 0.561$). In other words, decrease in viscoelasticity means increase in dynamic modulus, showing development of the leaves' tissue. Indeed, we have observed this phase delay of polymers that have been thermally degraded by thermal chain scission (e.g. polyvinyl chloride⁵ and polypropylene¹³ and by thermal cross-linking of acrylonitrile-butadiene and chloroprene rubbers⁶, accompanied by regression in viscoelasticity. Hence, by analogy we infer that delay in phase corresponds to degree of development of the leaves' tissues. These developed tissues have complicated structures (spongy mesophylls and veins) arranged in a flat plane perpendicular to the propagation direction of the waves. As a result, viscoelasticity can be used as an evaluation of

development of the leaves' tissues, without thickness measurement.

2. Dynamic viscosity and imaginary parts in complex waves

To determine modulation of the propagated wave patterns for vegetative leaves, we pay attention to Nyquist diagrams¹⁹ for the propagated waves. The Nyquist dia-

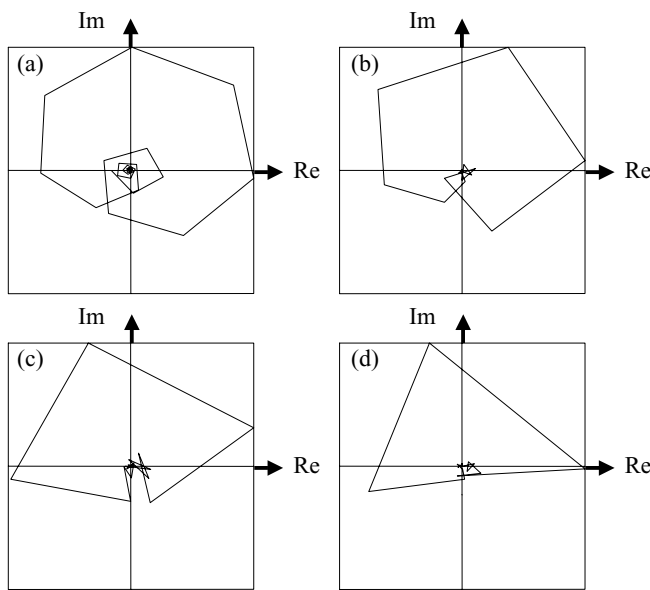

Fig. 4. Nyquist diagram of the propagated waves for representative four tea leaves

(a): $d = 0.048$ mm, (b): $d = 0.224$ mm,
(c): $d = 0.646$ mm, (d): $d = 1.182$ mm.

grams for the representative 4 tea leaves with different thickness are presented in Fig. 4. As thickness increases, the diagram changes from hexagon shape ($d = 0.048$ mm) to pentagon ($d = 0.224$ mm), square ($d = 0.646$ mm) and triangle ($d = 1.182$ mm) ones in turn, and the area of the third and the fourth quadrants in the loop decreases. The decrease of the apex number means frequency convergence in power spectrum, showing development of the fibrous tissues, accompanied by increase in rigidity. Even if we have more counting runs, this tendency persists. The decrease in the area suggests restoration of relay in phase, that is, decrement of imaginary parts in complex waves.

Last we investigate properties of the leaves in terms of viscosity. To distinguish botanical development of external appearance and internal tissues, the thickness dependence of the attenuation coefficient and dynamic viscosity are presented in Fig. 5. As thickness increases, the damping ratio decreases linearly except large damping in thin young leaves, and the viscosity decreases with wide dispersion ($r = 0.769$). The decrease in the viscosity reversibly correlates with increase in dynamic modulus in Fig. 2. In other words, this is a viscoelastic manifestation of the developed leaves. We can actually see the fibrous effect in the fiber-reinforced materials¹. Judging from the above-mentioned results and discussions, we can regard the leaves as natural quasi- polymers with high viscoelasticity.

Furthermore, we cannot make clear maturation of the tea leaves using acoustic properties. This interesting area needs further study. In our further study, attention will be given to the acoustic interactions of chloroplast

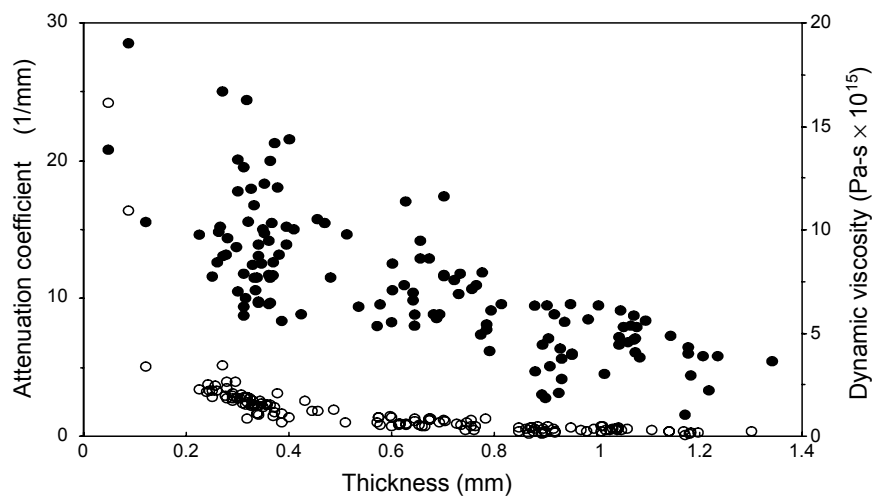

Fig. 5. The thickness dependence of attenuation coefficient and dynamic viscosity for tea leaves

The correlation coefficient between thicknesses and dynamic viscosity is 0.769.

○ : Attenuation coefficient, ● : Dynamic viscosity.

tissue associated phase modulation¹² and frequency variation. The nondestructive VRP method will also be a probe useful in sap physiology, fluid pathology and the study of many other kinds of leaves.

Conclusion

We have shown that the acoustic characteristics of dispersive fresh tea leaves are determined nondestructively by ultrasonic transmission analysis. As thickness increases, phase velocity and wavelength increase, and damping ratio and dynamic viscosity decrease, suggesting development of the fibrous tissues, accompanied by frequency convergence. The velocities of all the leaves studied were smaller than that of pure water. This may be raised from the internal structure with loosely packed parenchyma cells. Decrease in viscoelasticity corresponds to increase in dynamic modulus. Acoustically, we can regard the leaves as natural quasi-polymers with high viscoelasticity. Thus, the VRP method is capable of providing an acoustic evaluation of the fundamental characteristics of fresh leaves.

References

1. Davidge, R. W. (1979) Mechanical behaviour of ceramics, Cambridge University Press, London, 111.
2. Del Gross, V. A. & Mader, C. W. (1972) Speed of sound in pure water, *J. Acoust. Soc. Am.*, **52**, 1442–1446.
3. Dengler, N. G. (1987) Leaf. *In* Encyclopedia of science & technology, 6th, ed., McGraw-Hill, New York, 637–643.
4. Fukuhara, M. & Sampei, A. (1996) Low-temperature elastic moduli and dilational and shear internal friction of polycarbonate. *Jpn. J. Appl. Phys.*, **35**, 3218–3221.
5. Fukuhara, M., Kuwano, Y. & Oguri, M. (1996) Determination of thermal degradation of heated polyvinyl chloride using diffracted SH ultrasonic waves. *Jpn. J. Appl. Phys.* Pt.1, **35**, 5B, 3088–3092.
6. Fukuhara, M. et al. (1999) Determination of thermal degradation of vulcanized rubbers using diffracted SH ultrasonic waves. *J. Polym. Sci., Pt. B: Polym. Phys.*, **37**, 497–503.
7. Fukuhara, M. et al. (1999) A trial study of nondestructive for plant by ultrasonic waves passing through tea leaf. *In* The 20-th ultrasonic electronics symposium, Tokyo, 237–238.
8. Fukuhara, M. et al. (2000) Propagation characteristics of leaves using ultrasonic transmission waves. *Acoust. Lett.*, **24**, 70–74.
9. Fukuhara, M. (2002) Acoustic characteristics of botanical leaves using ultrasonic transmission waves. *Plant Sci.*, **162**, 521–528.
10. Fukuhara, M. & Tsubouchi, T. (2003) Naphthenic hydrocarbon oils transmissible for transverse waves. *Chem. Phys. Lett.*, **371**, 184–188.
11. Fukuhara, M., Yin, F. & Kawahara, K. (2004) Acoustic characteristics of high damping Mn₇₃Cu₂₀Ni₃Fe₂ alloy. *Phys. Stat. Sol.(a)*, **201**, 454–458.
12. Kline, R. A. (1984) Measurement of attenuation and dispersion using an ultrasonic spectroscopy technique., *J. Acoust. Soc. Am.*, **76**, 498–504.
13. Kuwano, Y. et al. (1996) Determination of thermal degradation of polypropylene by use of diffracted SH ultrasonic waves. *In* The proceeding of the first symposium for polymer analysis, ed. Jpn. Soc. Chem. Analysis, Inst. Nagoya Tech., Tokyo, 155–156 [In Japanese].
14. Maeda, Y. (1957) Dynamic viscoelasticity, polymers. *In* Jikken kagaku koza Vol.8 (Lecture on experimental chemistry), Maruzen, Tokyo, 155 [In Japanese].
15. McBumey, T. (1992) The relationship between leaf thickness and plant water potential. *J. Exp. Botany*, **43**, 327–332.
16. Mobley, J. et al. (1999) Measurements and predictions of the phase velocity and attenuation coefficient in suspensions of elastic microspheres. *J. Acoust. Soc. Am.*, **106**, 652–659.
17. Nakamoto, K., Oku, T. & Hayakawa, S. (1996) Photosynthetic characteristics of tea leaves growth under field conditions. *Seibutsu kankyo chosa (Environ. Control in Biol.)* **34**, 277–283 [In Japanese].
18. Nolle, A. W. & Sieck, P. W. (1952) Longitudinal and transverse ultrasonic waves in a synthetic rubber. *J. Appl. Phys.*, **23**, 888–894.
19. Nyquist, H. (1932) Regeneration theory. *Bell Syst. Tech. J.*, **11**, 126–147.
20. Sachse, W. & Pao, Y.-H. (1978) On the determination of phase and group velocities of dispersive waves in solids, *J. Appl. Phys.*, **49**, 4320–4327.

